

Filling depositor

For Rondolino, a completely new filling depositor has been developed, using impeller technology. It can handle fillings of various consistencies, from low to relatively high viscosity, with or without particles. It can also handle two fillings simultaneously, a different filling in each of the two hoppers. Depositing is continuous and discontinuous from one to four rows. The flexible exit tubes allow different depositing patterns, from the normal straight line pattern to off-set depositing for filled triangles. The position on the line of the filling depositor can be chosen at wish.

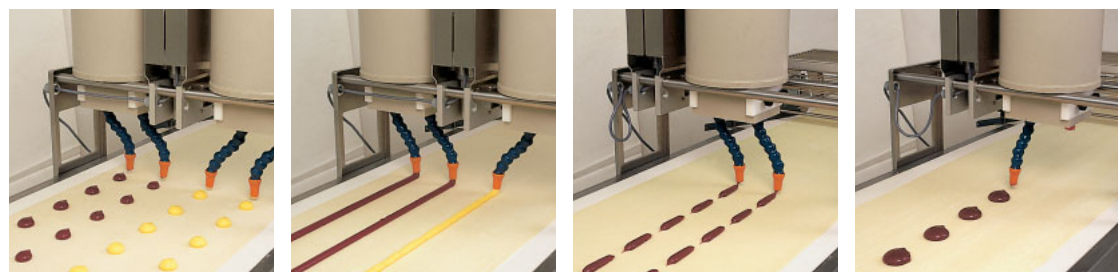

Filling depositor		ZFGR
Technical Data		
Hopper content	12 l	
Types of Filling	Low and relatively high viscosity fillings, with and without solid particles.	
Max temperature of filling	40 °C	
Modes of depositing	continuous spot spot without belt stop	
Number of outlets	1 to 4	
Quantity of filling per outlet	continuous mode: 10–100 g spot: 3–60 g	
Drive	DC gear motor	

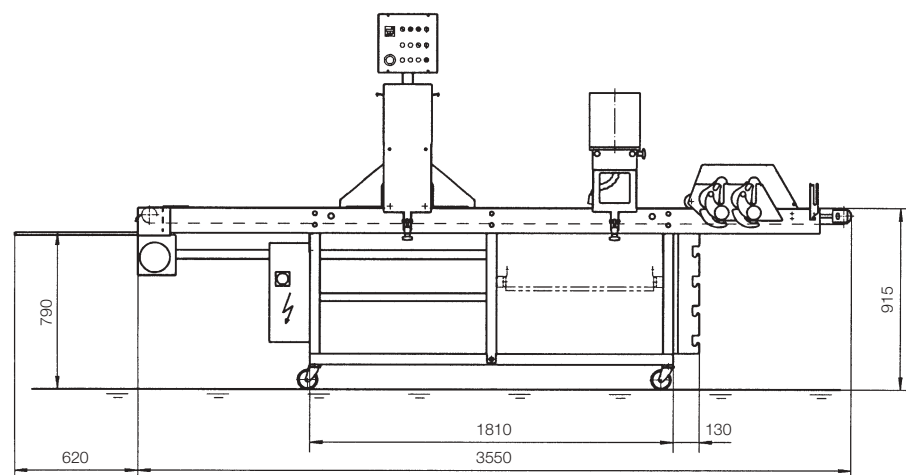

Guillotine		ZGM 635
Technical Data		
Total Length	670 mm	
Total Width	800 mm	
Passage of safety guard	35 mm	
Control voltage	24 VDC	
Drive	AC-gear motor	
a) Cutting		
Width of cross-cutting knife	610 mm	
Usable width	600 mm	
Cutting length min.	10 mm	
No. of strokes	70/min	
b) Stamping		
Stamping length max.	170 mm	
Stamping width max.	580 mm	
No. of strokes max.	50/min	
Dough thickness max.	15 mm	

Rondolino		SFT 370
Technical Data		
Table width	715 mm	
Conveyor belt width	640 mm	
Table length overall	3550 mm	
Height	915 mm	
Speed of conveyor belt	0,8–7,0 m/min.	
Rated power	1,5 kVA incl. accessories	
Supply voltage	3 x 200–420 V, 50/60 Hz	
Control voltage	24V DC	

Subject to technical changes without notice.
The type specific and the safety instructions of the operating manuals as well as the prohibition, mandatory action and warning signs are to be observed.

Quality is the basis.



RONDO DOGE

SEEWER AG
CH-3400 Burgdorf/Schweiz
Telefon 034 420 81 11
Fax 034 420 81 99

SEEWER GmbH & Co.
D-57299 Burbach
Hoorwaldstrasse 44
Telefon (02736) 203-0
Fax (02736) 203130

SEEWER RONDO S.à.r.l.
PAE «Les Pins»
67319 Wasselonne Cédex
Téléphone 03 88 59 11 88
Fax 03 88 59 11 77

RONDO LTD.
Unit 7, Chessington Park
Lion Park Avenue
Chessington, Surrey KT9 1ST
Great Britain
Telephone 0181-391-1377
Fax 0181-391-5878

Further subsidiaries in:
USA, Canada, Italy

Rondolino.

The ideal pastry line for the craft baker.



Automatic cutting and filling, combined with manual finishing – There is no limit to your creativity.

The automatic dough band positioner brings the dough into a pre-defined alignment with the cutting rollers.

Rondolino.
A modest investment with an exceptional price-performance ratio:
 – for minimum floor space
 – for maximum performance

With Rondolino a dream comes true for all small to medium size bakeries. On a minimum of floor space, a large variety of pastry products can be produced either automatically or semi-automatically in high quality and consistency. With Rondolino the craft baker finally gets a tool to considerably reduce his production costs.

Accessories, such as filling depositor and guillotine all have electro-mechanical drives. The guillotine cuts and stamps almost noiselessly and free of vibration. Synchronizing depositing with cutting or stamping is easy: to position the filling correctly, the guillotine may be slightly moved along the line. In fact, the position of the guillotine can be chosen at wish.

It can even be placed in front of the filling depositor. This way, a number of special products, such as cookies and Danish pastries can be rationally produced in a semi-automatic way.



Filled, folded and cut or stamped products, with or without decorations, in almost limitless variety.



For double decker products, the mechanical dough band positioner can be fitted in the middle of the line.