

# SM-80/120/160/200MAG-R



Glimek SM-MAG-R Spiral Mixer consists of a range of mixers with removable bowls. Reliable and easy to handle for all kind of bakeries. Manual, automatic or semi-automatic function for guiding between low and high speed.



Sveba Dahlen Group

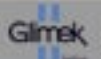
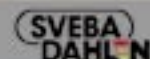

Scandinavian know-how – worldwide

# SM-80/120/160/200MAG-R



The control panel has push buttons for on/off, automatic/manual, slow/fast, clockwise/anticlockwise and three electrical timers with digital LED display

Jog function for dough emptying



Opening and closing of the machine can be made on both left and right hand side of the machine

Both the mixing spiral and the bowl can rotate clockwise and anticlockwise

## Technical data SM-80MAG-R

Capacity	
Flour	50 kg
Dough	80 kg
Power supply	
1 st speed	3,7 kW
2nd speed	6 kW
Bowl	0,75 kW

## Measurements SM-80MAG-R

Width	720 mm
Depth	1430 + 360 mm
Height	1660 + 75 mm
Weight, net	650 kg
Weight, gross (wooden crate)	735 kg
Volume, gross	1,60 x 0,85 x 1,70 = 2,31 m <sup>3</sup>

## Technical data SM-120MAG-R

Capacity	
Flour	75 kg
Dough	120 kg
Power supply	
1 st speed	3,7 kW
2nd speed	8 kW
Bowl	0,75 kW

## Measurements SM-120MAG-R

Width	785 mm
Depth	1500 + 360 mm
Height	1660 + 75 mm
Weight, net	700 kg
Weight, gross (wooden crate)	785 kg
Volume, gross	1,68 x 0,92 x 1,84 = 2,84 m <sup>3</sup>

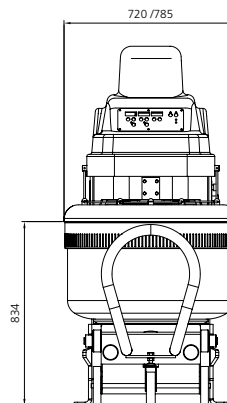
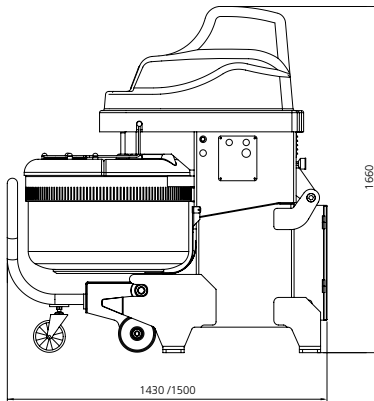
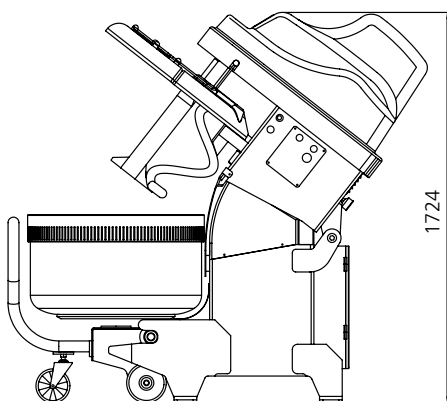

Specify the bowl size by order, for example SM-80MAG-R for 80 kg dough and SM-200MAG-R for 200 kg dough



**Glimek AB**

Box 124  
S-280 64 GLIMÅKRA  
Sweden

Tel. int. +46-(0)44 449 00 • Fax +46-(0)44 449 10  
e-mail: office@glimek.se • www.glimek.se