

SM-160/200AR Spiral Mixer



Glimek SM-160/200AR Spiral Mixer includes an overturnable system for emptying the bowl. The lifting system lifts up the whole machine when emptying. This system is available for 160 kg and 200 kg dough.



Sveba Dahlen Group

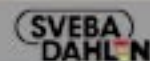

Scandinavian know-how – worldwide

SM-160/200AR Spiral Mixer



The safety guard opening system of 180 degrees facilitate the feeding of ingredients



Manual, automatic or semi-automatic function for guiding between low and high speed

Separate bowl drive for rotation in both directions

Jog function for dough emptying

Accessories

Discharge on two sides

Discharge in two different levels, one level for discharge onto table

Technical data

	SM-160AR	SM-200AR
Dough capacity	160 kg	200 kg
Flour capacity	100 kg	125 kg
Bowl volume	260 lit	305 lit
Bowl diameter	850 mm	910 mm
Floor to bowl rim height	1140 mm	1140 mm
Power of spiral 1st speed	7,5 kW	7,5 kW
Power of spiral 2 st speed	10,5 kW	10,5 kW
Bowl power	0,75 kW	0,75 kW
Hydraulic bowl	1,1 kW	1,1 kW
Maximum width	1900 mm	1900 mm
Maximum length	2150 mm	2150 mm
Maximum height	3265 mm	3265 mm
Maximum overall height	3340 mm	3340 mm
Maximum discharge height	2020 mm	1990 mm
Base width	1110 mm	1110 mm

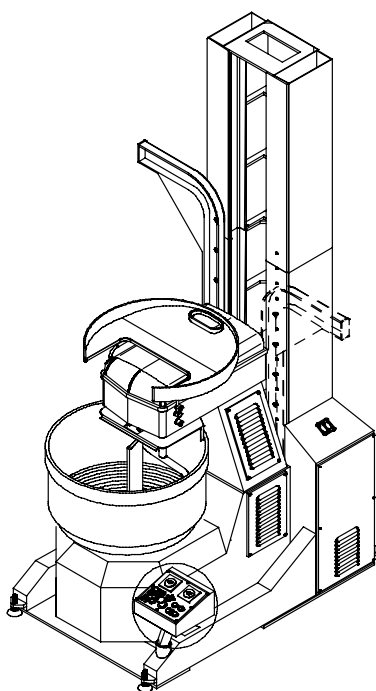

Specify the bowl size by order, SM-160AR for 160 kg dough and SM-200AR for 200 kg dough
Left or right hand version has to be specified by order
Discharge onto table or into a divider has to be specified by order



Glimek AB

Box 124
S-280 64 GLIMÅKRA
Sweden

Tel. int. +46-(0)44 449 00 • Fax +46-(0)44 449 10
e-mail: office@glimek.se • www.glimek.se