

SD-300 Dough Divider



Glimek SD-300 is an automatic suction-feed dough divider which can be used either as 1-pocket or as a 2-pocket. The strong construction of the SD-300 is adapted to heavy-duty production.



Sveba Dahlen Group



Scandinavian know-how – worldwide

SD-300 Dough Divider



PLC control including a touch screen with menu based system including speed in pcs/h, piece counting, preset counting, fine tune of the belts and a reference scale for the weight
Separate control for outfeed belt



Easy to switch from 1-pocket to a 2-pocket



Dough knife in stainless steel direct connected to the hopper provides an optimal emptying of the hopper

The dividing mechanism from high quality Ni-resist steel ensures a high weight accuracy

Oilreservoir 11 lit, easy to fill

Accessories

| | |
|---|---|
| Flour duster, mechanical | Flour duster on the first conveyor, mechanical |
| Hopper 225 litre | Dough Hopper 225 lit, approximately 150 kg dough (Standard is 100 lit 70 kg dough) |
| Hopper lubrication for 225 litre hopper | Automatic lubrication inside the dough hopper, by means of a spread tube system |
| Non-stick coating of hopper 100L | Interior of the dough hopper 100L non-stick to assure a smooth infeed of the dough |
| Non-stick coating of hopper 225L | Interior of the dough hopper 225L non-stick to assure a smooth infeed of the dough |
| Oiling of belt | Oiling device for oiling the first conveyor belt |
| Special belt | Special customized belt on one or both conveyors |
| Non stick coating of dough scraper | Dough scraper in non stick to ensure correct ejecting of sticky dough on the conveyor |
| Transfer roller | Support driven roller at the end of the outfeed conveyor, for sticky dough |

Technical data

| | |
|-------------------------------|--|
| Capacity range | |
| 2-pocket | 1500 - 3000 dough pieces/hour |
| 1-pocket | 750 - 1500 dough pieces/hour |
| Weight range | |
| 2-pocket SD-300 | 40 - 400 grams |
| 1-pocket SD-300 | 100 - 1000 grams |
| 2-pocket SD-300 XL | 150 - 1150 grams |
| 1-pocket SD-300 XL | 250 - 2300 grams |
| Power Supply | 1,62 kW |
| Weight, net | 685 kg |
| Weight, gross (carton+pallet) | 745 kg |
| Volume, gross | 1,80 x 1,50 x 1,92 = 5,18 m ³ |
| dB(A) | 73 |

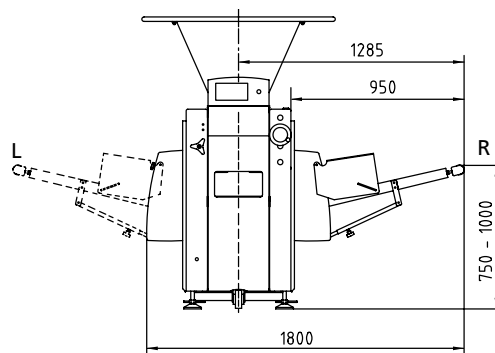
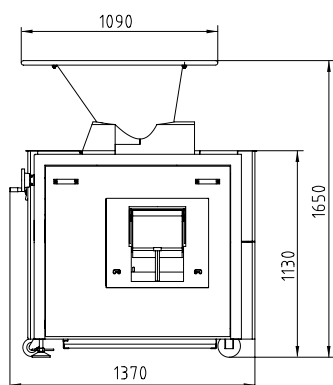

Left (L) or right (R) outfeed has to be specified by order



Glimek AB
Box 124
S-280 64 GLIMÅKRA
Sweden
Tel. int. +46-(0)44 449 00 • Fax +46-(0)44 449 10
e-mail: office@glimek.se • www.glimek.se